



How Google Plans To Use AI To Reinvent The \$3 Trillion US Healthcare Industry

每日免费获取报告

- 1、每日微信群内分享**5+**最新重磅报告；
- 2、每日分享当日**华尔街日报**、金融时报；
- 3、每周分享**经济学人**
- 4、每月汇总**500+**份当月重磅报告
(增值服务)

扫一扫二维码

关注公众号

回复：**研究报告**

加入“起点财经”微信群。



Google is betting that the future of healthcare is going to be structured data and AI. The company is applying AI to disease detection, new data infrastructure, and potentially insurance. In this report we explore Google's many healthcare initiatives and areas of potential future expansion.

Google has always seen itself as more than a search and advertising company.

Now it's turning its focus to healthcare, betting that its AI prowess can create a powerful new paradigm for the detection, diagnosis, and treatment of disease.

In short, Google seems to be going after the healthcare space from every possible angle.

For example, did you know that Google has a project to release sterilized mosquitoes to control the spread of infectious disease? Or that the company has started a limited commercial rollout of its diabetes management program? Or that it appears to be exploring insurance?

So tomorrow, if AI can shape healthcare, it has to work through the regulations of healthcare... In fact, I see that as one of the biggest areas is where the benefits will play out for the next 10–20 years.

– Sundar Pichai
CEO OF GOOGLE

In this analysis, we dive deep into how Google is pushing healthcare forward with a focus on data and AI, including:

- The specific disease areas where Google is studying diagnostics and management – including diabetes, Parkinson’s Disease, and heart disease, among others
- How Google is rebuilding the healthcare data infrastructure layer to potentially become the new data pipes for health giants
- Possible areas of expansion, including hardware for providers, insurance and more
- How Google could make eventually money off its many disparate healthcare bets
- Obstacles between where the company is today and where it’s trying to go

Note: For simplicity we use “Google” as shorthand for the larger Alphabet company, under which many of these healthcare initiatives fall. We explain the Alphabet structure below.

Table of contents

- 1 [Google's structure & AI advantage](#)**
 - Google prioritizes AI
 - Google's structure
- 5 [How Google is using AI to tackle specific diseases](#)**
 - Eye disease
 - Diabetes
 - Heart disease
 - Parkinson's disease
 - Multiple sclerosis
- 16 [Powering the healthcare data infrastructure layer](#)**
 - Creating data pipes for health giants
 - Pushing Google Cloud
 - Building datasets for third parties
- 23 [Google in health going forward](#)**
 - Disease areas
 - Tools for doctors
 - Diagnostics for patients
 - Population health interventions
 - Google insurance
 - How will Google make money of its healthcare initiatives?
- 36 [Can Google pull it off?](#)**

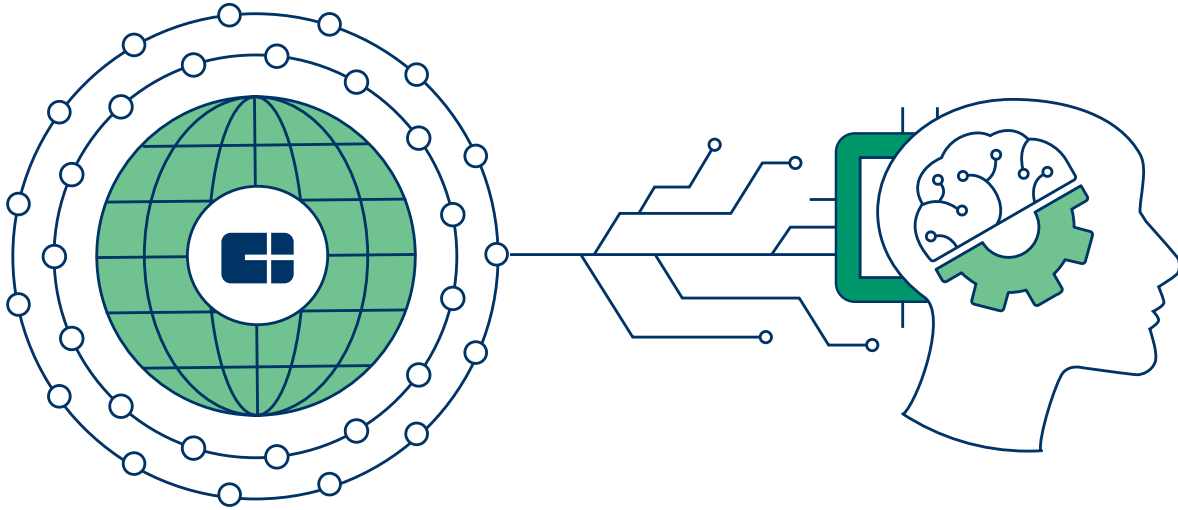

At CB Insights, we believe the most complex strategic business questions are best answered with facts.

We are a machine intelligence company that synthesizes, analyzes and visualizes millions of documents to give our clients fast, fact-based insights.

From Cisco to Citi to Castrol to IBM and hundreds of others, we give companies the power to make better decisions, take control of their own future—and capitalize on change.

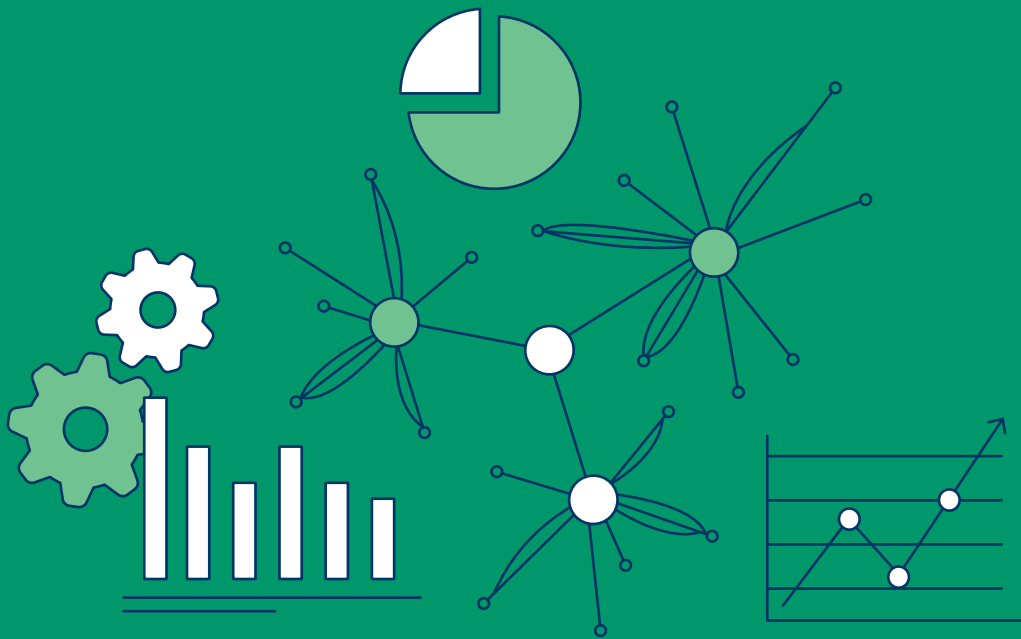

WHERE IS ALL THIS DATA FROM?

The CB Insights platform
has the underlying data
included in this report

[CLICK HERE TO SIGN UP FOR FREE](#)



“We use CB Insights to find emerging trends and interesting companies that might signal a shift in technology or require us to reallocate resources.”

Beti Cung,
CORPORATE STRATEGY, MICROSOFT



TRUSTED BY THE WORLD'S LEADING COMPANIES



Be the smartest person in the room

Check out more of our research
and expert intelligence.



[GOOGLE IN HEALTHCARE
COLLECTION](#)



[VERILY INVESTOR PROFILE](#)



[APPLE IN HEALTHCARE
RESEARCH BRIEF](#)

Google's structure & AI advantage

GOOGLE PRIORITIZES AI

As Google enters healthcare, it's leaning heavily on its expertise in AI. Health data is getting digitized and structured, from a new electronic record standard to imaging to DNA sequencing. Google is both helping speed up this process by creating new means of ingesting health data and betting that it can use AI to make sense of the data quickly and potentially more accurately than current methods.

Among the big 5 tech giants (Facebook, Apple, Microsoft, Google, Amazon), Google emphasizes its progress on machine learning much more than the rest.

Google is emphasizing it's an AI/ML company

Mentions of "Machine Learning" in earnings transcripts, 2013 - 2017

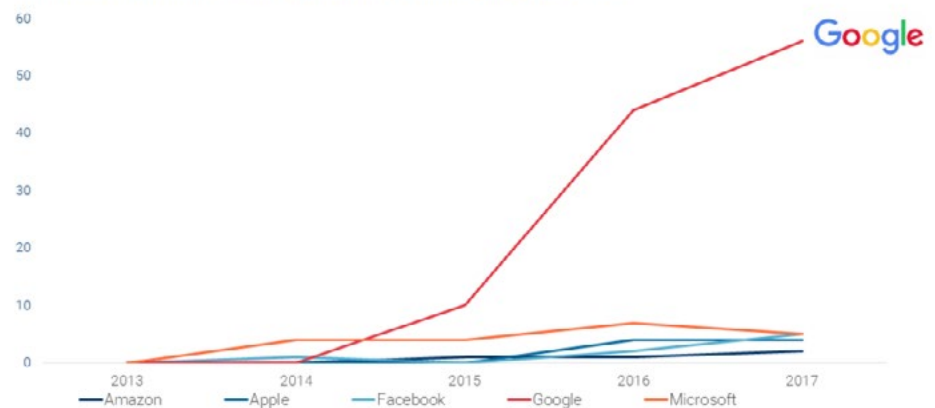

CBINSIGHTS CB Insights Earnings Transcript Database

As software, and more specifically artificial intelligence, becomes a differentiating factor in the healthcare space, Google is well-positioned.

The company is doubling down on the number of research papers it publishes, opening more AI research centers around the world, and developing its own chips and hardware dedicated to running AI/ML processes. In addition, Google is the most active investor/ acquirer of AI companies among big tech companies, scooping up talent and building relationships with up-and-coming AI applications.

WHAT BIG TECH COMPANIES ARE DOING IN AI			
COMPANY	INVESTMENTS 2012 – 2017 YTD	ACQUISITIONS 2012 – 2017 YTD	SELECT INTERNAL PROJECTS
			A9 Amazon Lex (powers Alexa) Apache MXNet Amazon Polly Amazon Rekognition Amazon Go
		 R E G A I N D	Siri Core ML Neural engine Project Titan
			The Network. Intuitive.
		 	M Big Basic Caffe2 DeepMask/SharpMask
	 		Predix.io
	 	 	Google Home DeepMind Google Brain TensorFlow, TPU Quantum AI Waymo
			Watson TureNorth PowerAI
	 	 	Loihi Intel Nervana (powers next gen intel chips like Knights Mill)
	 	 	Cortana Azure ML platform Cognitive Toolkit Project Brainwave Microsoft Pix 2nd gen. Holographic Processing Unit
			Adaptive Intelligent Apps Oracle Autonomous Database cloud

GOOGLE'S STRUCTURE

In 2015 Google restructured into Alphabet, and AI become the centerpiece of nearly each division's strategy. In that restructuring, healthcare projects, which previously had fallen within the R&D labs of Google X (Google's secretive special projects lab), instead moved to new subsidiaries at the company.

To an extent, this restructuring siloed Google's health initiatives a bit more – but also pushed them beyond the “moonshot” arena into specific subsidiaries with a tighter set of mandates.

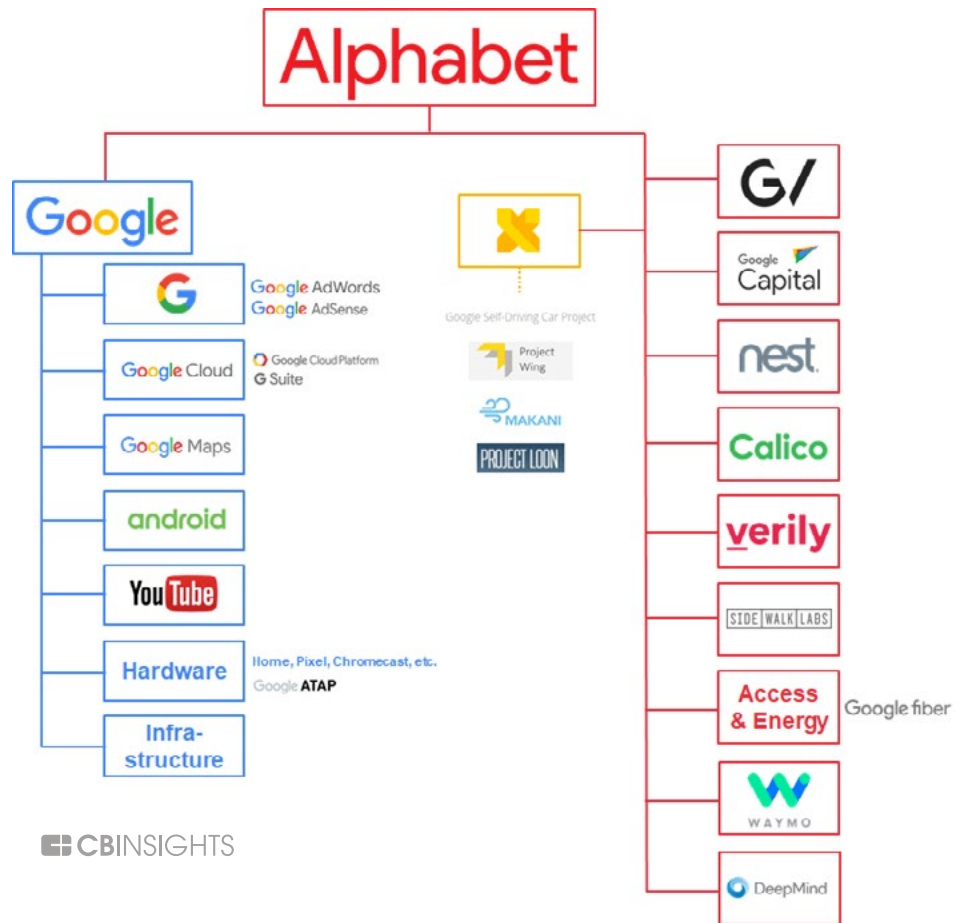

The three subsidiaries focused in healthcare are Verily, DeepMind, and Calico.

Verily – Verily is where Alphabet is doing the bulk of its health-care work. The subsidiary is focused on using data to improve healthcare via analytics tools, interventions, research, and more.

Verily is run by Andrew Conrad, who co-founded the National Genetics Institute. The subsidiary has largely focused on partnering with existing healthcare institutions to find areas to apply AI, especially via its Study Watch, a wearable device that captures biometric data. The Study Watch, which is currently awaiting FD approval, has become a centerpiece of a number of research initiatives discussed below.

The company has recently increased its exposure to startups by setting up a lab space to work beside startups like **Freenome** and **Culture Robotics**. Verily has also said it's looking into international expansion via an \$800M investment from Singapore sovereign wealth fund Temasek Holdings and investing as a limited partner into Europe-based **Medixci Ventures**.

DeepMind – DeepMind is dedicated to artificial intelligence research. One of its main initiatives is finding ways AI can be

applied to healthcare. DeepMind was acquired by Google for \$500M+ and is run by Demis Hassabis. The company is based in London and works closely with National Health Service institutions.

Calico – Calico focuses on learning about and then combating aging and age-related diseases. The subsidiary uses AI to make sense of large datasets as well as to automate certain lab processes. Calico is run by ex-Genentech CEO Arthur Levinson.

Google has also invested heavily into the healthcare space through its venture arm GV.

GV – The venture arm invests across different sectors, but has been increasing its investing pace in healthcare companies, while its overall investing pace has slowed.

Google Ventures Increases Healthcare Investing

Number of Google Ventures Digital Health + Healthcare deals, 2013 - 2017

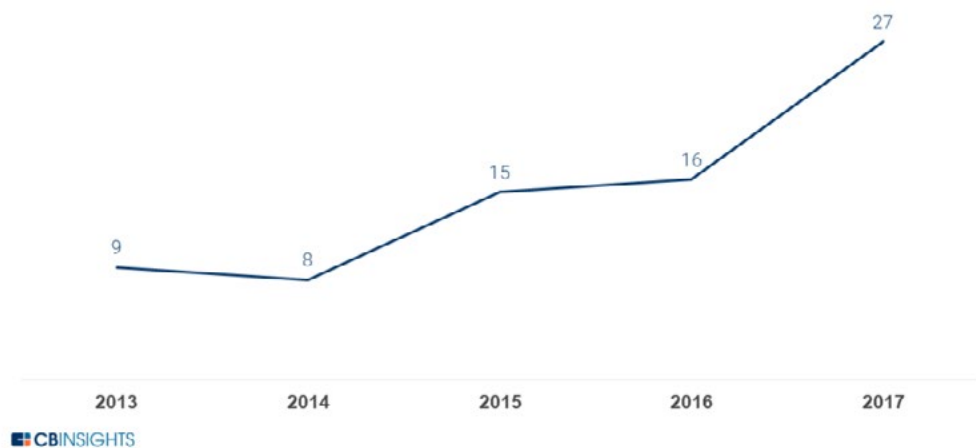

Below, we'll largely focus on healthcare initiatives at each of these subsidiaries, but will also discuss how other Google assets – such as Google Cloud, which sits outside of these key organizations – are being leveraged for healthcare.

2

How Google is using AI to tackle specific diseases

Using AI to tackle disease, from monitoring, to detection, to lifestyle management

Google's strategy involves an end-to-end approach to healthcare, including:



- **Data generation** – This includes digitizing and ingesting data produced by wearables, imaging, and MRIs among other methods. This data stream is critical to AI-driven anomaly detection.
- **Disease detection** – Using AI to detect anomalies in a given dataset that might signal the presence of some disease.
- **Disease/lifestyle management** – These tools help people who have been diagnosed with a disease or are at risk of developing one go about their day-to-day lives and/or make positive lifestyle modifications.

While most of these projects fall under Verily's purview, DeepMind is involved in several parts of disease detection and Google itself holds several patents under the parent company.

These are currently the main diseases Google is tackling with this approach. As shown below, work on these disease spans

organizations under the Alphabet structure. We'll dive deeper into each area.

Google is tackling specific diseases

	EYE DISEASE	DIABETES	HEART DISEASE	PARKINSON'S	MULTIPLE SCLEROSIS
Data Generation	Optos	Dexcom Glucose Monitor	Monitoring Patent + Study Watch	Study Watch	Study Watch
Disease Detection	Diabetic Retinopathy Research	Cardiogram Study	Retina Heart Health Analysis	Personalized Parkinson's	MS Observational Study
Disease/Lifestyle Management	Ocular Mount	Onduo + Smart Syringe	One Brave Idea	Liftware	Galvani Bioelectronics

CBINSIGHTS

EYE DISEASE

Verily is working on detecting diabetic retinopathy (a condition when high sugar levels cause damage to blood vessel in the eye) via a partnership with Nikon's subsidiary **Optos**, which makes the machines for retinal imaging tests and eye disease detection.

In earlier research, Google proved its algorithms were equally as good as trained ophthalmologists in detecting the condition.

Google's algorithms are matching doctors



"The results show that our algorithm's performance is on-par with that of ophthalmologists."

Performance of the algorithm (black curve) and eight ophthalmologists (colored dots) for the presence of referable diabetic retinopathy based on 9,000+ images.

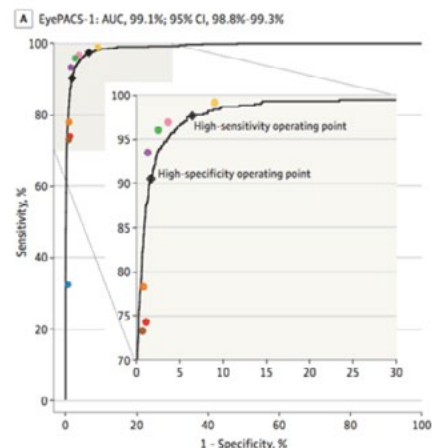

CBINSIGHTS Google

The DeepMind division is also working with the Moorfields Eye Hospital in the UK to improve on this prior eye disease research and assist eye doctors in assessing the risk of a patient's eye problem and directing them to medical care based on the urgency of the condition. In the current system, all anomalies are treated as urgent, even though there is a spectrum of severity.

Verily isn't only focused on detecting eye diseases, but also on potentially fixing certain diseases as well. Analyzing the frequency of words in Verily's granted patents reveals it has consistently filed patents related to contacts and eye implants.

Several of Verily's **patents** highlight ways to combat presbyopia (age-related eyesight degeneration) by using contact lenses to help focus vision. This is a project Verily is working on in conjunction with Alcon, a subsidiary of Novartis, though the project appears to have delayed its trials and its current status is unclear.

Verily Focuses On Corrective Eye Devices

Word frequency of Verily's published patents, 2013-2017

2013	2014	2015	2016	2017
polymer layer	wearable device	handheld tool	implanted device	optical beam
analyte sensor	magnetic particle	flexible substrate	eye mountable device	lens enclosure
eye mountable device	electrical contact	eye mountable device	pathology image	plunger head
second polymer	biological tissue	light source	handheld tool	wearable device
first polymer	response signal	electrical contact	magnified pathology	mountable device
bio compatible layer	analyte response	sensing device	data packet	polymer layer
compatible layer	power supply	contact lens	enclosure material	response signal
wearable device	bio compatible layer	accommodation actuator	second layer	measurement period
response signal	compatible layer	assistive device	magnetic nanoparticles	ophthalmic device
hydrophilic copolymer	target tissue	magnetic field	first layer	target person
mountable device	polymer layer	phase map	image sensor	reference image



DIABETES

Diabetes detection and management is a major healthcare focus for Google, which has already had some success rolling out products. Given the prevalence of diabetes – the condition affects 30 million people in the US alone – it makes sense that

this would be an area of attention.

Detection

In addition to combating presbyopia, the Alcon contact was also meant to monitor glucose through tears, and was one of Verily's first "moonshots" to be publicly announced. However, other experts have suggested that tears are not a reliable source for monitoring glucose.

Google's smaller continuous glucose monitor (CGM), which Verily created with medical device company Dexcom, is already farther into the commercialization pipeline. The Dexcom G6 monitoring system, which has been submitted to the FDA for approval, monitors levels of interstitial glucose right under your skin.

The long-term goal is to create an even smaller disposable sensor that can be worn for 14 days like a bandage and requires no finger stick calibrations (as opposed to the current G6, which requires a finger stick calibration once a day). This was mentioned in the Dexcom investor presentation as seen on the left.

The Future of CGM Technology



- Factory Calibrated
- 14 Day Use Life
- Real-Time CGM
- Single-use transmitter
- Significant cost reduction

The collaboration with Verily has also seen an increasing number of mentions in Dexcom's [earnings calls](#) over the last couple of years.

CB Mentions in Earnings Calls

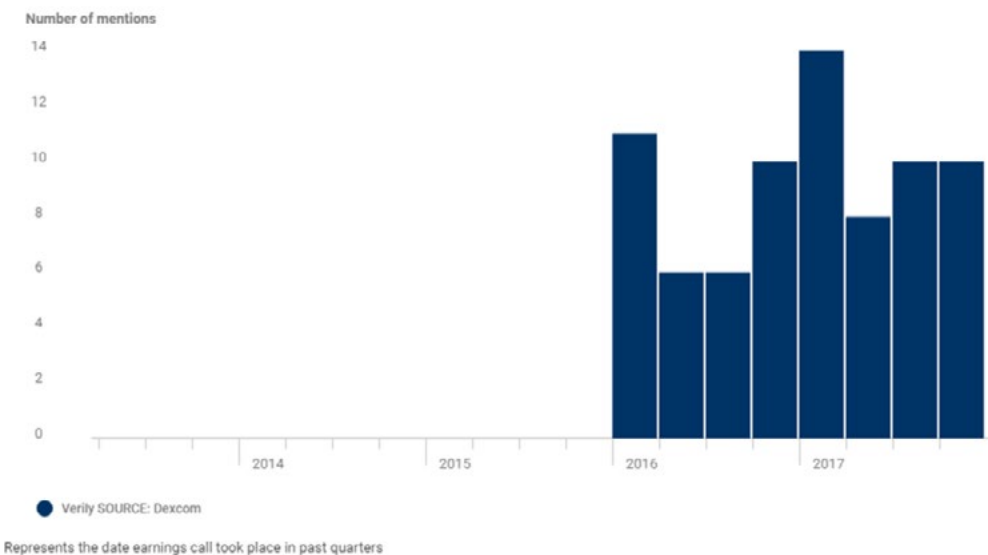

While diabetes management is relatively well understood, there's a gap in diabetes detection today.

Because your pancreas is connected to your autonomic nervous system, small changes in heart rhythm could potentially help detect development of the disease. [Cardiogram](#), a startup that uses heart rate to monitor and predict disease, recently released a study that used existing wearables, including the Android Wear, to detect diabetes with 85% accuracy using AI and heart rate.

This kind of detection could be a potential area of expansion for Verily if it looks to improve its early detection of diabetes.

Management

Verily is also leveraging multiple partnerships in the diabetes space by including the Dexcom monitors in the starter kit for [Onduo](#), its virtual diabetes management program that recently began its commercial launch.

Onduo is a joint venture between Sanofi and Verily, which have together invested \$500M into the solution. Using sensors and coaching, the company's goal is to help type 2 diabetics manage their condition.

Onduo is similar to other virtual diabetes programs like [Omada Health](#), which combine hardware (glucose monitors, smart scales, etc.), software, and coaching to help people with diabetes manage their condition. AI is useful here to detect at-risk patients and streamline the coaching process.

Google CEO Sundar Pichai mentioned in the Q1'18 earnings call that Onduo began a commercial launch of its diabetes program earlier in the year, likely targeting insurance carriers (based on its website, below) and employers (based on this [study](#) working with supermarket employees in the Netherlands).

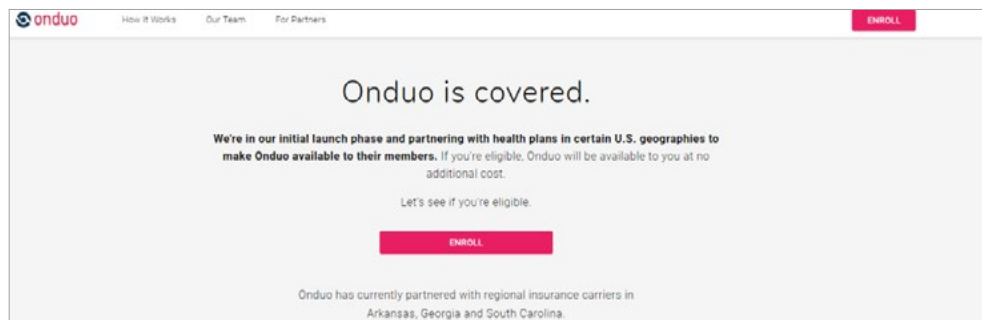

Verily also recently **patented** a smart syringe to help diabetics monitor their injections. The syringe will likely be part of the Onduo solution.

Google patents a smart syringe to properly track dosages

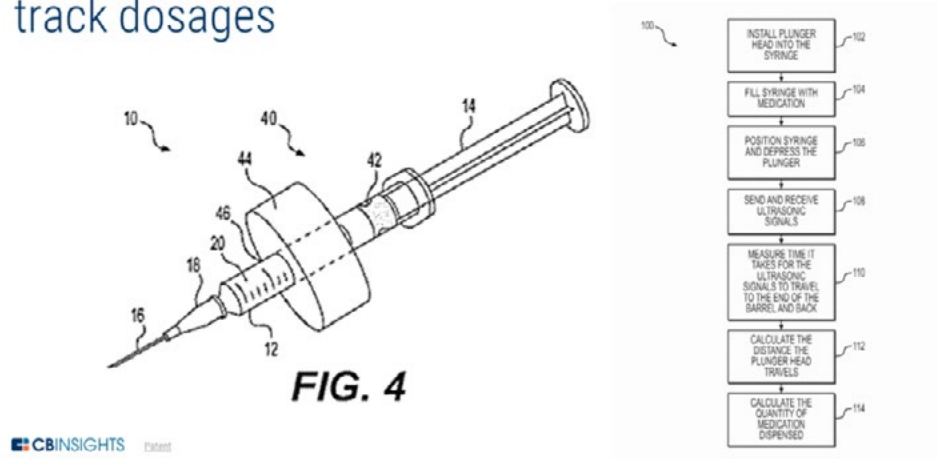

While Onduo is currently focused on type 2 diabetes, it has mentioned moving into type 1 diabetes management in the future as well. Startups making AI-powered medical devices that help manage type 1 diabetes automatically like **Bigfoot Biomedical** are developing this kind of closed-loop system for type 1 diabetes.

Bigfoot Biomedical creates an automated insulin dispensing solution by combining a continuous glucose monitor, an insulin infusion pump, and software to optimize insulin delivery automatically. This area could be one Verily chooses to move or acquire into.



Google patents passive heart monitor

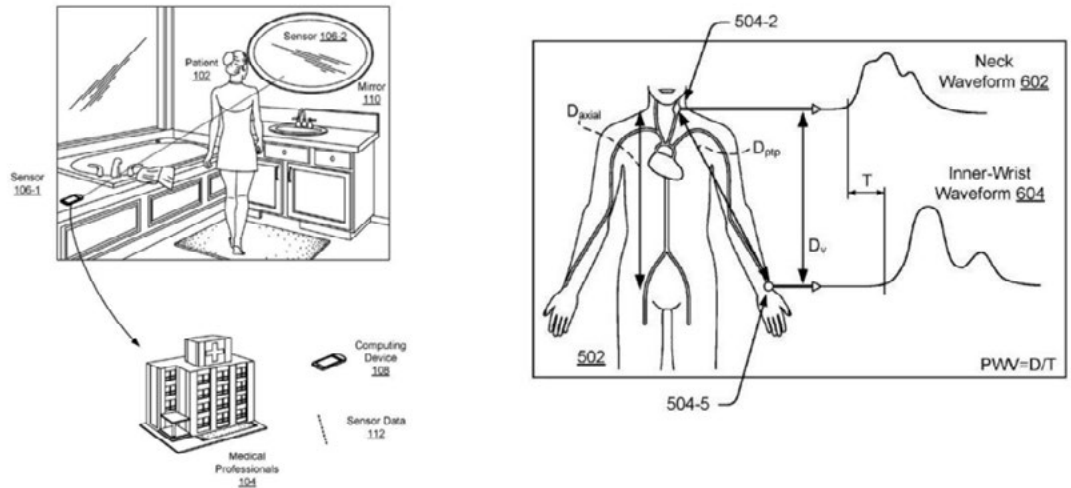

CBINSIGHTS

42

HEART DISEASE

Currently Google is approaching data generation and heart condition monitoring in two ways.

The first is via the Study Watch, produced by Verily and used by researchers to monitor different biomarkers of study participants. This includes both an electrocardiogram (ECG) and heart rate monitor, which researchers can use to help detect anomalies earlier and to better understand what other factors might lead to or be precursors to heart episodes. This could help in identifying better predictors of heart disease earlier in the development of the condition.

The second is highlighted in a [patent](#) for a passive heart monitor using optical sensors and machine vision that seems more catered towards the everyday person. The patent talks about taking images of key blood flow areas to provide a continuous monitoring of heart health in order to promote more healthy behaviors.

The patent also has a disease detection component, detecting blood flow issues in areas like the brain for stroke detection or detecting cardiac abnormalities like an arrhythmia, which could indicate cardiovascular issues.

Google is also looking to help providers detect cardiovascular issues via retinal images. The company published a [paper](#) on how its machine learning algorithms were able to detect risk for

CBINSIGHTS

11

cardiovascular issues by analyzing the blood vessels in the eye. Below are fundus images of the eye, with the green lines being the areas that the neural network used to make its predictions.

Images of the fundus of the eye

Green areas represent blood vessels the neural network is analyzing

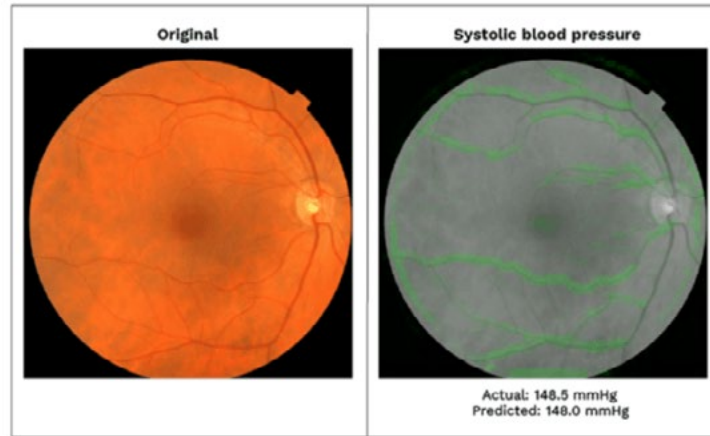

CBINSIGHTS NERVIX

To help patients who are at higher risk of developing cardiovascular disease or who already have heart conditions, Verily has participated in a \$75M grant to One Brave Idea, a project from Dr. Calum MacRae, chief of cardiovascular medicine at Brigham and Women's Hospital. The project aims to better understand the factors that contribute to different types of heart disease, as well as methods of preventing heart disease and potentially reversing it. The grant was given in conjunction with AstraZeneca and the American Heart Association.

While details on the project are still vague, it's possible that Verily will eventually move to create a lifestyle management system similar to Onduo for people at risk for heart disease.

PARKINSON'S DISEASE

Parkinson's disease is a debilitating neurological disorder that is poorly understood. Now, Verily is trying to figure out the underlying causes of the disease by capturing and analyzing data to produce earlier disease identification, personalized treatments, and improved management.

Verily launched the Personalized Parkinson's Project with Radboud University in the Netherlands to combine clinical data

with patient data collected by the Study Watch, including heart functionality, electrodermal activity, and inertial movements.

One hope is that with 24-hour monitoring researchers will be able to identify indicators of disease onset, such as changes in heart rhythm or sleeping patterns. Another hope is that Verily can use data from the project to build algorithms that can segment Parkinson's patients and hopefully personalize the treatments.

Through the Personalized Parkinson's study, Verily developed an encrypted database of deidentified data for researchers to use. It's building a similar database for the NIH called the Knowledge Portal as well, allowing researchers to share and visualize datasets related to Parkinson's research.

Through this work, Verily and researchers hope to find earlier indications of the onset of the disease, understand how it progresses, and potentially find new ways to create therapies for people with the disease.

In the meantime, Verily is also looking at ways to help Parkinson's patients manage their day-to-day lives. This began with the acquisition of [Lift Labs](#), creator of the Liftware spoon that helps Parkinson's patients stabilize their food while eating. The spoon and related attachments are sold for \$195 and up.



LIFTWARE



- Multiple attachments**
Including a soup spoon (included with Starter Kit) and others available for purchase separately.
- Computerized stabilization**
Advanced sensors, motors, and an onboard computer work to actively detect and counteract your tremor.
- Rechargeable battery**
Battery will last for several days on a charge.



Timeline: 2010 (\$100k), 2011 (\$150k), 2013 (\$1M), 2014 (Acquired by Google), Total Funding \$2M



According to patents it's filed, Verily is exploring other ways to use the Liftware tool to help people with neurological disorders. For example, this [patent](#) suggests the spoon can be used to detect the mass of food and number of bites taken per meal to ensure that patients are getting adequate nutrition. This is useful information for caregivers and providers that are helping manage patients with neurological disorders.

MULTIPLE SCLEROSIS

Multiple sclerosis is also a disease without a known cause or cure. MS is the result of the immune system attacking the myelin sheath in the brain, causing deterioration of muscle control, memory loss, and more.

Verily is working with biotech company Biogen and Brigham and Women's Hospital to set up a longitudinal study to understand how the disease develops. This combines data from participants wearing the Study Watch with clinical data fed into Verily's machine learning algorithms to improve detection and understand what causes the disease to progress and flare up.

Verily hasn't explicitly talked about management of the disease. However, there's been exploratory research into using electroceuticals to combat MS, which could inform a project Verily is pursuing with GlaxoSmithKline called **Galvani Bioelectronics**. The project uses miniature electronics to control how electrical signals flow throughout the body. Electroceuticals are very small electronic implants that help modulate the flow of electrical signals through the nervous system.



How small would a bioelectronic device be?

Because it would attach to a nerve, we're working to develop the device to be as small as a grain of rice.

It's possible that Galvani's bioelectronics could be used to help manage MS as it progresses. Notably, Verily has a [job posting](#) for neuromodulation, suggesting it will explore the area.

In addition, Google could eventually help people manage the disease by creating external solutions that help people with impaired motor functions. Exoskeleton companies like [ReWalk Robotics](#) help people with impaired motor function stay mobile by combining software, sensors, and electronics.

COMPANIES HELPING THE MOBILITY IMPAIRED WITH EXOSKELETONS



Funding

\$11.4M (Public)

Rewalk Robotics builds soft exoskeletons to help people recover from strokes and neurological disorders

Select Investors

ProSeed Venture Capital, SCP Vitalife, YASAKAWA Electric

SIMILAR COMPANIES



3

Powering the healthcare data infrastructure layer

One of the biggest challenges in healthcare is that data is heavily siloed and there's very little interoperability between systems.

It can be difficult to integrate data across differing EMRs even within the same hospital, not to mention data across mobile apps, connected devices, and other health-tracking products. In fact, while **79%** of doctors believe that having all available patient data in one place is critical to their jobs, only 14% could access EMR information across different departments, patient care centers, etc., even within the same hospital.

Google believes it can be a part of the solution by powering a new data infrastructure layer via 3 key efforts:

- 1 Create new data pipes for health giants
- 2 Push Google Cloud
- 3 Build Google's own healthcare datasets for third parties

CREATING DATA PIPES FOR HEALTH GIANTS

In order to increase interoperability among hospitals, physicians, and other relevant parties, the industry is slowly shifting to a new technology known as FHIR (Faster Healthcare Interoperability Resources). FHIR creates standards for different data elements so that developers can build application programming interfaces (APIs) that can be used to access datasets from different systems.

Google is betting that accessing, organizing, and interpreting this data is going to be the future of healthcare. The company acquired API management company **Apigee** for \$625M in 2016. One part of Apigee's business is dedicated to building healthcare APIs using FHIR.

Apigee has already worked with several high-profile healthcare companies, including McKesson, Cleveland Clinic, Walgreens, and more, and its system helps build bridges between data streams. Use cases include connecting multiple existing datasets that otherwise wouldn't be able to communicate with each other, using Apigee to build out an organization's mobile apps, and finding new ways to ingest data from other sources (e.g. wearables).

Apigee aims to use FHIR to create APIs and enable interoperability



Industry Challenges

- Regulation change, technology advancement, and consumer expectations drive industry change.
- Focus on payment for outcomes instead of for services requires new business models.
- Requirements for health data interoperability demand infrastructure modernization.



Digital Initiatives

- Open data initiatives reveal new opportunity for providers to connect with patients, and across healthcare systems in new ways.
- FHIR ((Fast Healthcare Interoperability Resources) standard for data interoperability provides framework for data interoperability and compliance.
- Changes from the point of care to payment and reimbursement improve outcomes and overall provider and payer effectiveness.



Apigee Intelligent API Platform



API Foundation

Increase agility, reduce development time, leverage data, and grow ecosystems with API-based infrastructure



Data Interoperability

The Apigee Health APIx solution provides a fast path to data interoperability across healthcare teams



Intelligent Apps

Unlock and leverage health data to enable intelligent and adaptive apps for multiple devices



IoT Platform

Enable use of sensors and remote monitoring allowing healthcare providers to connect with patients in new ways

Google's DeepMind is also building a new data infrastructure through its initiatives. DeepMind is looking for ways to apply artificial intelligence and analytics to improve healthcare. To accomplish this, the organization needs access to data in usable, consistently structured formats.

DeepMind's first step is to build a new data infrastructure so that separate, siloed data from EMRs, hospital equipment, and doctor's

notes flow into a singular place in one standard format.

Using FHIR, DeepMind built a new data backbone to make it easier to build apps that can analyze different data elements.

For example, the company unveiled its "Streams" app to detect acute kidney injuries by pushing relevant patient information and alerts to doctors, nurses, etc. via a mobile app. This reduces the number of humans involved in escalating the severity of a case, which is especially useful when a case is time sensitive.

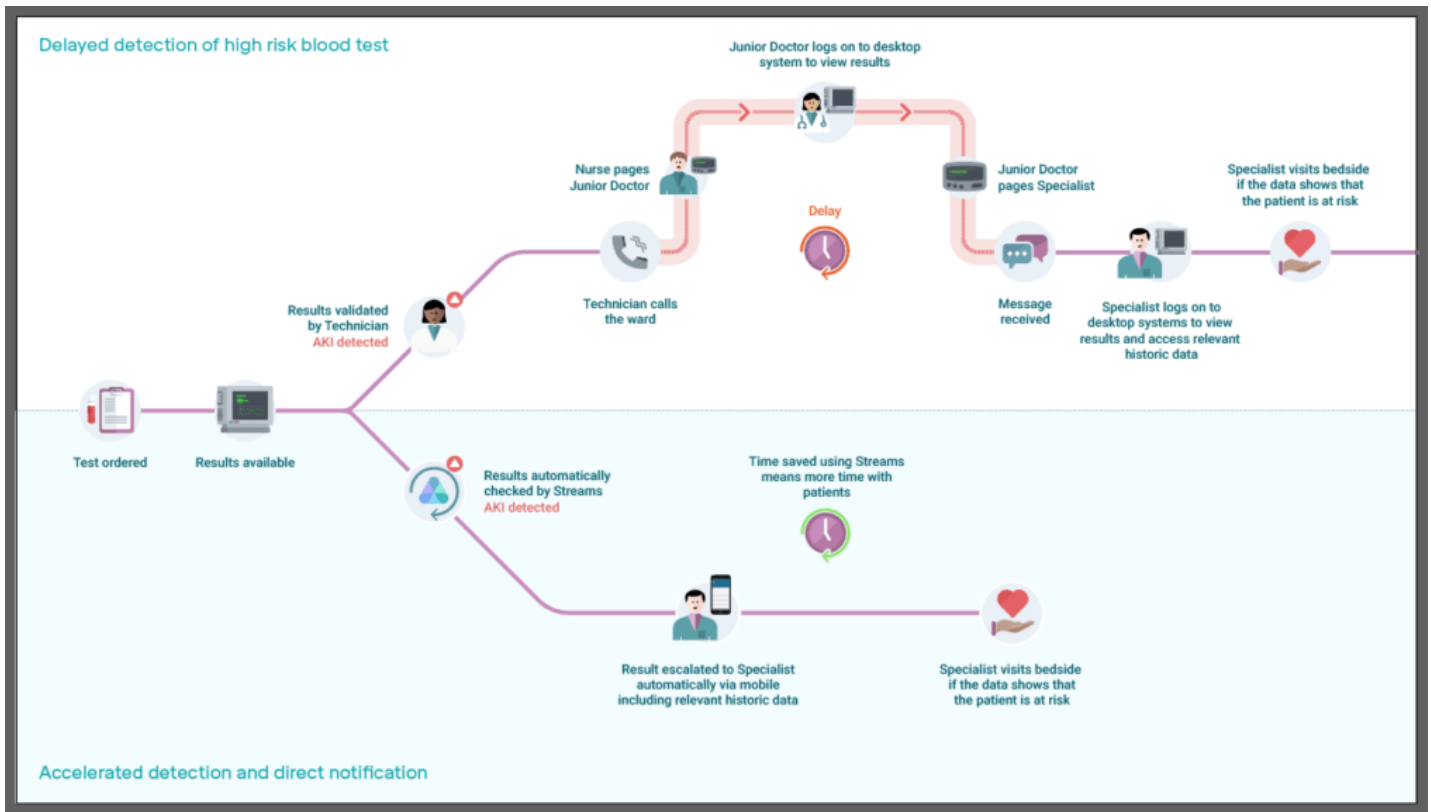

DeepMind plans to build more of its own apps or allow third-party developers to build on top of this new infrastructure. The organization could eventually charge companies to build on top of its data infrastructure or use it as a means of upselling a suite of other Google services like Google Cloud.

DeepMind health data infrastructure plan

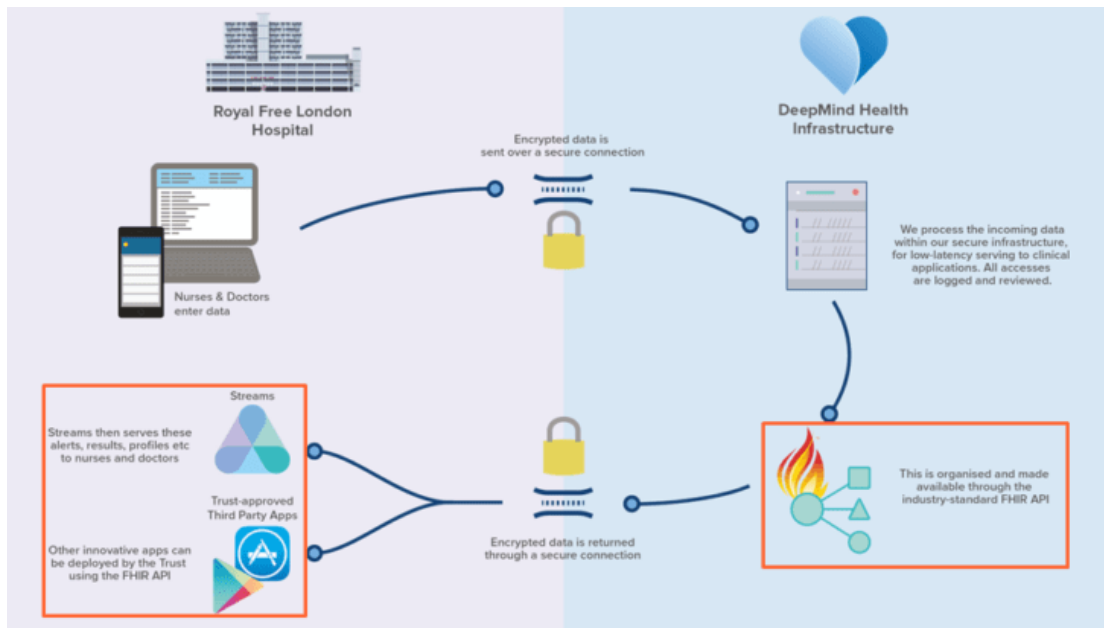

PUSHING GOOGLE CLOUD

Google has been pushing its Google Cloud platform aggressively in the last few years, especially after hiring ex-VMware CEO Diane Greene to lead the division. The company is competing with cloud platforms from other tech giants, including Amazon Web Services and Microsoft Azure, among others.

To compete, Google is pushing healthcare-specific services that are built on top of the Google Cloud platform. One example is Apigee, mentioned earlier, which offers API management as part of the Google Cloud suite.

Another example is the G Suite (Drive, Docs, etc.) for healthcare businesses. G Suite offers a HIPAA-compliant cloud service that healthcare businesses can use to share patient information, improve the patient experience (e.g. using Google Hangouts), and more. The G Suite offering describes building a flexible solution outside of existing EMRs, recognizing the challenges they pose for healthcare institutions.

This effort is still relatively new, however, and as yet the company does not mention any major healthcare clients using G Suite for patient tracking.

Google offers G Suite for healthcare practitioners built on top of its cloud offering

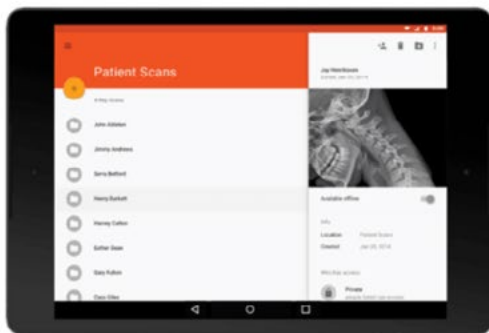

Streamline operations by going paperless.

- Collaborate more efficiently by sharing X-rays, CT scans, and voice and video messages as digital files (up to 5TB each) on Drive.
- Access files through Google's secure environment to minimize the constraints of EHR/EMR applications.
- Eliminate inconsistent and outdated versions of documents.

 CBINSIGHTS

Finally, Google could begin to roll out more Google Cloud-based open-source tools specific to healthcare researchers. There's a precedent for open-source tools: Google provides a suite of more general tools for developers, such as TensorFlow for AI. Recently, the company released its open-source DeepVariant deep learning tool for genomic analysis.

DeepVariant demonstrates another advantage Google has in the space over Amazon and Microsoft – it can test its products with its own in-house life sciences team, Verily. There’s a good chance Google will release more healthcare-specific open-source tools in the future, coming out of its own lab projects.

Daphne Koller, former chief computing officer at Google’s anti-aging research firm Calico Labs, [spoke at our A-ha! conference](#) about the use of machine vision tools to track footage of yeast cells aging, instead of a human manually watching hours of tape. Use of internally developed machine vision tools for healthcare research could be another suite Google releases in the future.

As more researchers build on top of the Google Cloud product suite, Google Cloud becomes more valuable to that team, and Google becomes a more ingrained part of the healthcare infrastructure.

Why Google Cloud Platform?



Future-Proof Infrastructure

Secure, global, high-performance, cost-effective and constantly improving. We’ve built our cloud for the long haul.



Seriously Powerful Data & Analytics

Tap into big data to find answers faster and build better products.



Serverless, Just Code

Grow from prototype to production to planet-scale, without having to think about capacity, reliability or performance.

BUILDING DATASETS FOR THIRD PARTIES

In addition to plugging into the data streams of the existing health system, Google is also building its own datasets that others could eventually integrate into their own research.

The two major data projects Verily is working on are the All of Us Research Program in conjunction with the NIH and Verily’s own standalone Project Baseline Study.

The All of Us Research Program (formerly known as the Precision Medicine Initiative) aims to track the health data of 1M participants from diverse backgrounds. This includes genomic data, lifestyle data, biomarker data, and more. The goal is for a community of researchers to analyze the most comprehensive dataset to discover novel insights about our health.

Verily was tapped by the NIH in 2016 and given a 5-year grant

alongside the Broad Institute and Vanderbilt University to build out the data infrastructure and analysis tools to house the data from the first 79,000 participants. However, recently All of Us has run into issues around coordination, as well as concerns that it is too expensive and ambitious to accomplish its goals.

We are building a research program of 1,000,000+ people

The mission of the *All of Us* Research Program is to accelerate health research and medical breakthroughs, enabling individualized prevention, treatment, and care for all of us.

ABOUT THE SCALE & SCOPE

environment lifestyle biology

Research focuses on the intersection of 3 factors

This may help explain why Verily is also engaging in its own research run entirely by Google. Verily's Project Baseline is working to create its own dataset from 10,000 voluntary participants over 4 years. Once enrolled, participants monitor their everyday activities using a Study Watch, use a sleep sensor to monitor sleeping patterns, answer periodic survey questions via mobile or email, and visit a participating site 4 times a year for a variety of tests.

Verily's informed consent form suggests that the company is building out a comprehensive database that third-party researchers might eventually be able to access and build on.

Baseline’s Informed Consent suggests the dataset will be used for other researchers to access and build on

“By signing this consent, you are allowing the Baseline Team to keep all of the information you provide in a database, called the Baseline Database...”

In the future, the Baseline Team may allow the data to be used by researchers outside of the Baseline Team. If this happens, the Baseline Team will not include direct identifiers (name, street address, phone number, and email address).”



Project Baseline

It’s also worth noting that data for both All of Us and Project Baseline is stored in Google’s Cloud infrastructure.

As researchers build on top of these datasets, it will help make Google Cloud a deeper part of the general Health IT infrastructure.



Google in health going forward

Google is regularly expanding its roster of healthcare initiatives. Below are a few other places where Google could expand in the healthcare space going forward, including new disease areas, applications of its AI technology, and even health insurance.

DISEASE AREAS

Other areas Google may explore next include Chronic Obstructive Pulmonary Disease (COPD), cancer, mental/behavioral health, and aging.

The next diseases to tackle?

	COPD	CANCER	MENTAL + BEHAVIORAL HEALTH	AGING
Data Generation	Study Watch	Freenome + MRI/CT images	Search data	Calico (data from mice)
Disease Detection	Senosis Health	Tumor detection research	Quartet Health	Calico (aging process)
Disease/Lifestyle Management	Galvani Bioelectronics	Radiotherapy planning + peer support	Mobile based intervention and therapy	Calico (new drugs + lifestyle changes)

DISEASE PROGRESSION



COPD

Chronic lower respiratory disease, primarily COPD, which is caused by inflamed airways, is the third leading cause of death in the US.

However, like diabetes and cardiovascular disease, which Verily is already tackling, COPD can be managed with a combination of

lifestyle adjustments and therapies.

The Study Watch already captures environmental data, which can often be a trigger for lung inflammation – so it’s not hard to envision the Study Watch alerting wearers to environmental conditions that potentially trigger COPD.

In addition, **Senosis Health**, which Google acquired in 2017, could potentially be used to develop diagnostic tools and treatments for COPD. Senosis claims to be able to use an existing smartphone microphone as a spirometer to measure lung function, and additionally use smartphone cameras to measure hemoglobin levels, which is useful for detecting anemia. Anemia **is seen as a potential** comorbidity with COPD, and so these two datasets could augment each other in better understanding and treating COPD.

Google has yet to incorporate Senosis technology into its products but could in the future.

Another possibility is using the bioelectronics from Galvani, Verily’s project with GlaxoSmithKline that focuses on controlling how electrical signals flow throughout the body. GSK has suggested that Galvani could be used to treat asthma, another pulmonary disease, though specific details have not been mentioned.

Chronic Obstructive Pulmonary Disease

Senosis acquisition

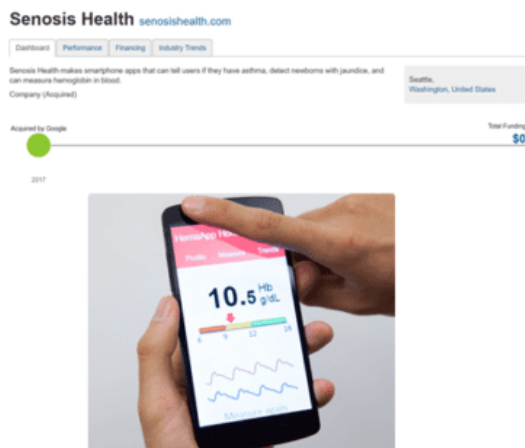

Galvani Electroceuticals use case?

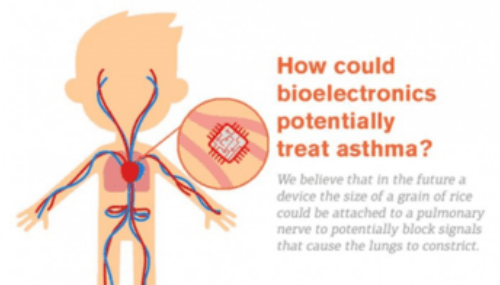

Source: GlaxoSmithKline

Different cancer types

Google has been researching different ways to identify and create treatment plans for cancer through its DeepMind division.

In 2017 the company released [research](#) regarding tumor identification, in which algorithms were trained on an existing set of images of breast cancer that had metastasized to adjacent lymph nodes. Algorithms could then detect tumors with 92% accuracy, allowing for some false positives (such as macrophages that might look like tumors).

Images of a lymph node biopsy with a breast cancer metastasis

Green areas represent possible tumors according to the algorithm

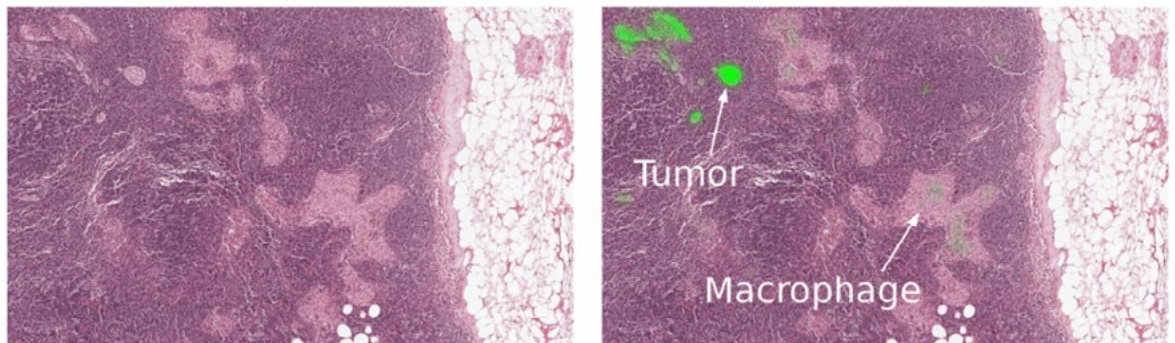

CBINSIGHTS Google

Since 2017, the company has partnered with the NHS and Cancer Research UK Centre at Imperial College London to further this research and improve early detection of breast cancer.

DeepMind is also working on other cancers like head and neck cancer. DeepMind's work in this area is more related to treatment design, with the company trying to apply AI to speed up the mapping process for determining where radiotherapy should be applied. The current mapping process takes approximately four hours – DeepMind believes it can shorten it to one.

Notably, Google has no means of generating this data itself, and instead partners with hospitals that then submit cancer data.

Verily's investment in **Freenome** could be a stepping stone in this direction as well. Freenome aims to detect cancer at earlier stages by detecting trace amounts of DNA that tumors shed into the blood stream (circulating tumor DNA).

Verily could also continue its partnership approach with a company like Siemens Healthineers or Phillips to gain access to MRI/CT images firsthand, and then use the data to build algorithms to improve detection and treatment planning.

Another possible area Google could explore is coaching and lifestyle management for cancer patients. In 2005 – 2006 Google was involved in a **study** related to connecting new cancer patients with cancer survivors as a form of peer guidance and navigation, though it appears no results came from that.

Cancer (various forms)

Freenome investment

Gap: Data stream from MRI and CT scans

Head and neck cancer radiotherapy planning

Peer to peer support networks

Study Design

Study Type	Interventional (Clinical Trial)
Allocation	Randomized
Intervention Model	Parallel Assignment
Masking	None (Open Label)
Primary Purpose	Educational/Counseling/Training
Official Title	Does a Peer Navigator Improve Quality of Life at Diagnosis?

Sponsor:
Stanford University

Collaborators:
California Breast Cancer Research Program
Genentech, Inc.
Amgen
Johnson & Johnson
Google Inc.

Information provided by:
Stanford University

CBINSIGHTS [Google.Clinicaltrials.gov](https://www.google.com/clinicaltrials)

Mental and behavioral health

Google could enter the behavioral health space by detecting patterns of mental health issues via searches. The company is already partnering with the National Alliance on Mental Illness (NAMI) to develop a questionnaire for users who search for depression systems.

Google Ventures has also invested in **Quartet Health**, a company that helps primary care physicians detect untreated mental health illnesses and guides patients to appropriate care. Quartet Health

could use its expertise and data to help Google detect behavioral health issues earlier.

Notably, Verily has an [open job posting](#) for a behavioral health program manager, which suggests that it's looking into this area.

Program Manager, Behavioral Health

South San Francisco, CA

Description

As a Program Manager in Behavioral Health at Verily you will focus on advancing initiatives focused on mental and behavioral health measurement and tech-enabled care capabilities. These projects require multi-functional solutions combining technology, data management and algorithmic techniques, with innovative care models, unique population health management tools and custom built physical assets. You will work closely with our software, design, clinical, and regulatory teams to coordinate the development of solutions from conception to launch. You will work closely with the technical and business development teams to manage the required pieces from both internal teams and external vendors and partners. You will also support and coordinate the relationship with other Verily teams that will be touched by these initiatives including Engineering, Clinical, Sales, Marketing, Regulatory and Finance.

Aging

Google spinout Calico is trying to understand the mechanisms that cause us to age. The company is looking at how different lifestyle changes, cellular processes, genetics, etc. [impact the course of aging](#). Through this process, Calico seeks to better understand disease detection and lifestyle management, and depending on what the division learns, it will probably also be involved in the data generation layer as well.

The company recently released research about the aging pattern of naked mole-rats and has announced partnerships to create aging-related drugs.

Studying other animal and biological systems to understand aging process

Naked mole-rat mortality rates defy Gompertzian laws by not increasing with age

J Graham Ruby, Megan Smith, Rochelle Buffenstein*

Calico Life Sciences LLC, South San Francisco, United States

Abstract The longest-lived rodent, the naked mole-rat (*Heterocephalus glaber*), has a reported maximum lifespan of >30 years and exhibits delayed and/or attenuated age-associated physiological declines. We questioned whether these mouse-sized, eusocial rodents conform to Gompertzian mortality laws by experiencing an exponentially increasing risk of death as they get older. We compiled and analyzed a large compendium of historical naked mole-rat lifespan data with >3000 data points. Kaplan-Meier analyses revealed a substantial portion of the population to have survived at 30 years of age. Moreover, unlike all other mammals studied to date, and regardless of sex or breeding-status, the age-specific hazard of mortality did not increase with age, even at ages 25-fold past their time to reproductive maturity. This absence of hazard increase with age, in defiance of Gompertz's law, uniquely identifies the naked mole-rat as a non-aging mammal, confirming its status as an exceptional model for biogerontology.

DOI: <https://doi.org/10.7554/eLife.31157.001>

New drugs and interventions

Google's Calico partners with new biotech firm to develop anti-aging and cancer drugs

March 24th, 2017

TOOLS FOR DOCTORS

Google is developing tools for doctors that are designed to augment their expertise. This can have particularly profound effects in areas where there is little or no access to skilled surgeons, physicians, etc., such as rural areas both in the US and internationally.

Additionally, Google is exploring how AI-enabled tools can help doctors in the hospital.

Verily partnered with Johnson & Johnson to create [Verb Surgical](#), a robotic surgery company that “involves machine learning, robotic surgery, instrumentation, advanced visualization, and data analytics,” according to its website.

Johnson & Johnson worldwide medical devices chairman Gary Pruden has [stated](#) that the goal of Verb Surgical is to democratize surgical skills:

*“The top 5% of surgeons can do things that the other 95% just can’t do, in terms of improving outcomes and procedures. If you travel around the world, it gets worse... **Our goal is to democratize surgery, to raise the standard of care by providing surgeon informatics, tools at the point of surgical care that will influence the outcome. We think that’s going to be the important tipping point.**”*

Verily has filed patents related to robotic surgery, including one [patent](#) that details a way for a robotic surgeon to make dissections using images generated prior to surgery, and [another](#) that involves using light on different types of biological tissue to understand where to cut.

Google also seems to be developing tools that can help conduct tests that require a high level of precision or have a high level of

variance between how doctors conduct tests.

One example is its **patent** for an automated abdominogular reflex test. This test requires a doctor to notice if a specific neck vein changes at the centimeter level. Google patented a combination of a pressure cuff, camera, and machine vision to supposedly conduct this test more accurately and with less disparity than when physicians conduct it.

Google moving into tools for doctors

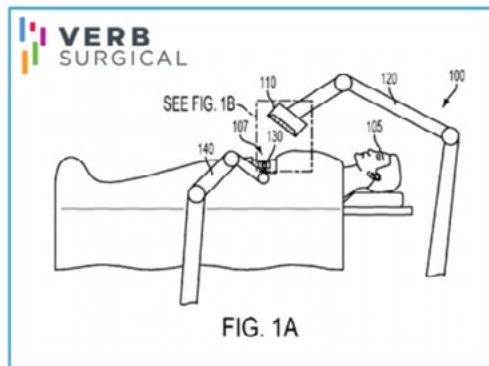

In conjunction with Johnson & Johnson, Verily is working on creating robots for surgeries. Some patents filed include ways to use existing images and lighting to partially or fully automatically conduct surgeries.

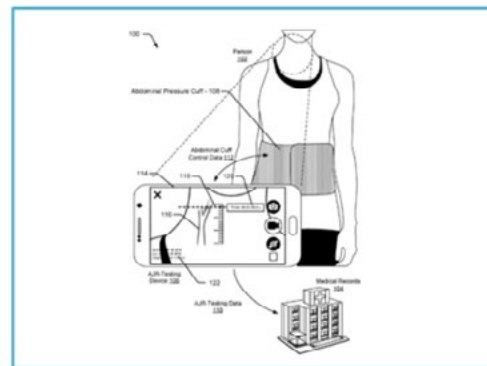

Google patented a combination of a pressure cuff, camera, and machine vision to help doctors conduct an abdominogular reflex test, which requires a high level of precision and has a large variance in how it's conducted by different doctors.

CBINSIGHTS CB Insights Patent Database

DIAGNOSTICS FOR PATIENTS

Google is primarily focusing on working directly with hospitals, healthcare providers, and researchers, rather than with patients and consumers.

However, the company does have some patient-facing health assessment tools, including the health cards it rolled out in 2015. The company partnered with the Mayo Clinic to provide disease information, symptoms, and treatments for common health conditions. This is similar to the use case for WebMD.

Google gives disease information via searches

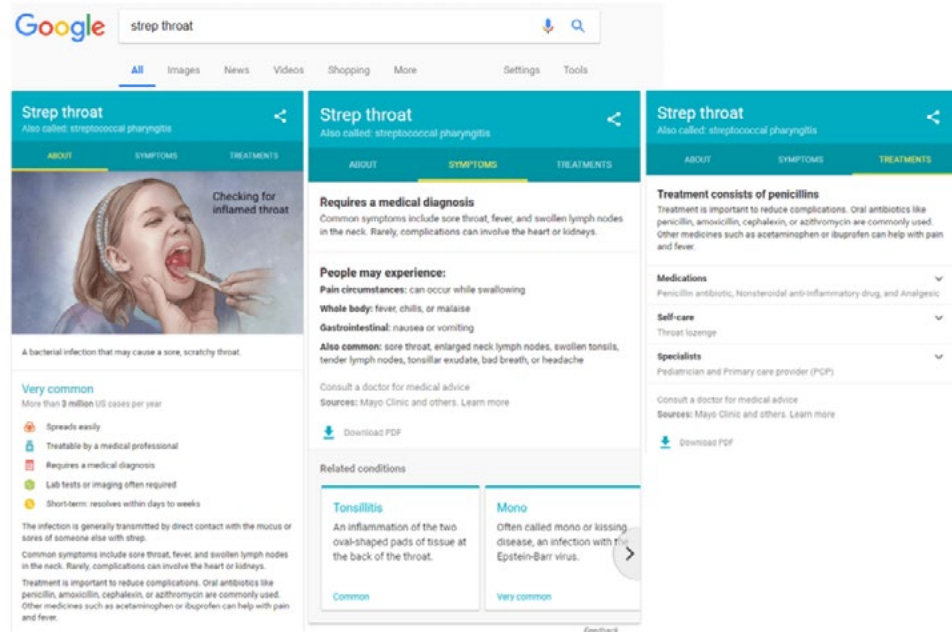

But Google has an opportunity to become more deeply involved in the screening and diagnosis of disease at the consumer level, especially as the area becomes more dependent on AI.

One possibility is using its new consumer hardware products for health screening. As Google continues to develop its Pixel phone, it could look to [Apple's initiatives in healthcare](#) via ResearchKit. Using existing hardware within the iPhone, Apple is trying to see whether consumers can screen for disease, and Google could do the same with the Pixel.

Another entry point into patient-facing health assessments could be the Google Home, Google's voice assistant. The tools could answer health-related questions similar to the health cards in search, and could eventually also be used to ensure medication adherence, help with disease-related lifestyle management, and ask follow up questions to assess a patient's risk level if other data streams detect some sort of health anomaly.

Google could also develop its own hardware for consumer diagnostics. It's developed a version for researchers through the Study Watch, but as it expands into consumer hardware it could bring those same sensors to its own line of wearables. It already counts steps, sleep, and more via sensors in the phone and through Android Wear, but creating clinical-grade data usable by physicians would move this hardware from wellness to healthcare.

The company is also looking at other wearables for use in diagnostic capacities. Google has a [patent](#) for a concussion test using a headset is reminiscent of Google Glass. While there hasn't been a lot of information about the concussion test, the patent talks about automating the eye, verbal, and motor tests used to place someone on the Glasgow Coma Scale, which assesses the severity of a brain injury.

Diagnostics for patients next?



Google's Pixel phone could be used for new diagnostic and screening capabilities, similar to the iPhone + ResearchKit.



The Google Home could be used to help screen for certain diseases via Q&A, or help with adherence and lifestyle management of disease.

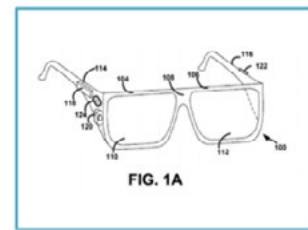

Google has a patent for a concussion test via a type of headset. Google could build new hardware with diagnostic capabilities, including a consumer version of the Study Watch.

POPULATION HEALTH INTERVENTIONS

Google is exploring ways that it can use AI to improve the health of large segments of the population at once.

One project the company is working on is Debug, which aims to engineer and release sterile mosquitoes into the population in order to eliminate disease-carrying mosquitoes. The company says it uses sensors and machine vision to sort between male and female *Aedes aegypti* mosquitoes and monitor them.

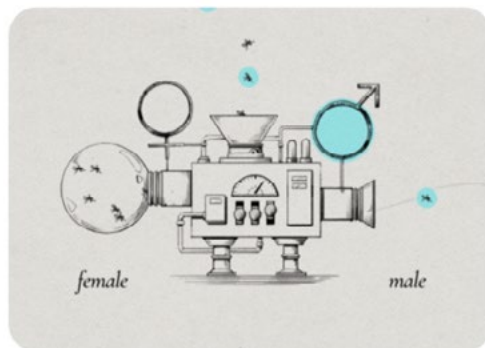

STEP 3

Separate

Male mosquitoes can't bite, so they don't spread disease. That's why we'll only release males. Separating male and female mosquitoes is currently a slow, manual process. We're developing new technologies that combine sensors, algorithms, and novel engineering to take advantage of unique aspects of mosquito biology to quickly and accurately sort males from females.

Another population health initiative comes from Google’s smart city division, **Sidewalk Labs**. One of Sidewalk Labs’ initiatives was looking at ways urban environments influence health. This effort eventually spun out into the Medicaid/Medicare-focused **Cityblock Health** company, which Sidewalk Labs then invested in.

Cityblock is creating in-person neighborhood health hubs that are close to areas with lots of Medicaid and low-income Medicare patients, to ensure these patients don’t fall off the grid and have access to care when they need it. The initiative also includes a health app called Commons, which connects care teams to these patients.

After gathering lots of data about Medicaid/Medicare recipients, a possible next step could be using AI as a means of triaging patients based on risk and intervening at appropriate times, in either a semi-automated or automated fashion.



Our technology

Health requires people to engage with one another openly and honestly; technology can help that happen better, faster, and more impactfully for our members. **Commons**—our easy-to-use platform for smartphones, tablets, and computers—enables members and their care teams to communicate, organize information and tasks, and work together toward goals.

Comprehensive

A multi-dimensional care summary chart tells the complete story of every member in a focused and consistent way to build common understanding across the team.



Task-driven

Task-management is central to the design, so members and their care teams can easily set and measure progress toward goals, manage their Member Action Plans, and prioritize next-steps.

Always on

Messaging and telehealth services allow all users to get and stay in touch any time of day, regardless of where they are.

Secure and private

All member data collected in Commons is stored in compliance with the Health Insurance Portability and Accountability Act’s (HIPAA) standards, which means that it is fully encrypted at rest and in transit. Access to this data is role-based and only granted to those who are explicitly given permission by our members.

Integrated data

Commons is also an integrated data platform that brings together health and community data sources of all types (including data from Electronic Health Records, Health Information Exchanges, claims, and more) to augment our understanding of our members.

Other far-off but nevertheless plausible areas where Google could pursue population health level interventions in the future include:

Cars — As **Waymo**, one of Alphabet’s other subsidiaries, continues to march into self-driving cars, there might be opportunities for Google to work to ensure passenger safety. Possible areas include monitoring the health of passengers, directing them to

care facilities if necessary, including tools for quick checkups/diagnostics within Waymo's network of cars, and more.

The car fleet could also be involved in bringing necessary medical supplies wherever they're immediately needed via nearby cars, instead of depending on ambulances. We've previously highlighted other ways [cars can impact healthcare](#).

Food – Health issues transmitted by livestock can lead to outbreaks further down the food chain. The ability to monitor animals and detect behavioral or physiological changes caused by disease could potentially reap public health benefits by catching these early.

A startup called [Cainthus](#) is attempting to solve this problem by monitoring livestock using machine vision. Google could also apply its machine vision technology to better help consumers detect whether their food has gone bad, as small changes in appearance can help indicate whether food has begun to breed certain bacteria.

Additionally, companies like Kewpie Corporation are already using Google's TensorFlow to track the ingredients that go into food.

GOOGLE INSURANCE

If Google believes that it can better detect and manage disease thanks to AI, it could become an insurance company and manage the risk of these patients.

Google appears to be exploring this area, with a [job posting](#) on the Verily site for a health plan executive.

“As the Health Plan Executive for Verily's Care Delivery Platforms, you will be responsible for supporting the design of Verily solutions used to manage risk for patient populations. Comfortable working in ambiguous situations, you will blend deep expertise of the health insurance industry, specifically managed care plans, with advanced technology solutions to improve outcomes and reduce costs.”

Some reports suggest that Verily is bidding for Medicaid contracts, which are currently in regulatory flux. However, Medicaid and Medicare together would make the most sense for Verily, considering its technology is focused on managing many chronic diseases which disproportionately affect these populations.

It's also worth noting that Google Ventures has investments in [Oscar](#), [Clover](#), and [Collective Health](#), which target individuals/small businesses, Medicaid, and self-insured populations, respectively. Verily could leverage the networks and expertise of these companies as it moves into Medicaid. The organization is reportedly looking at working to do this with Oscar in Rhode Island, and recently Verily invested in Oscar's latest fundraise alongside another Google investing subsidiary, capitalG.

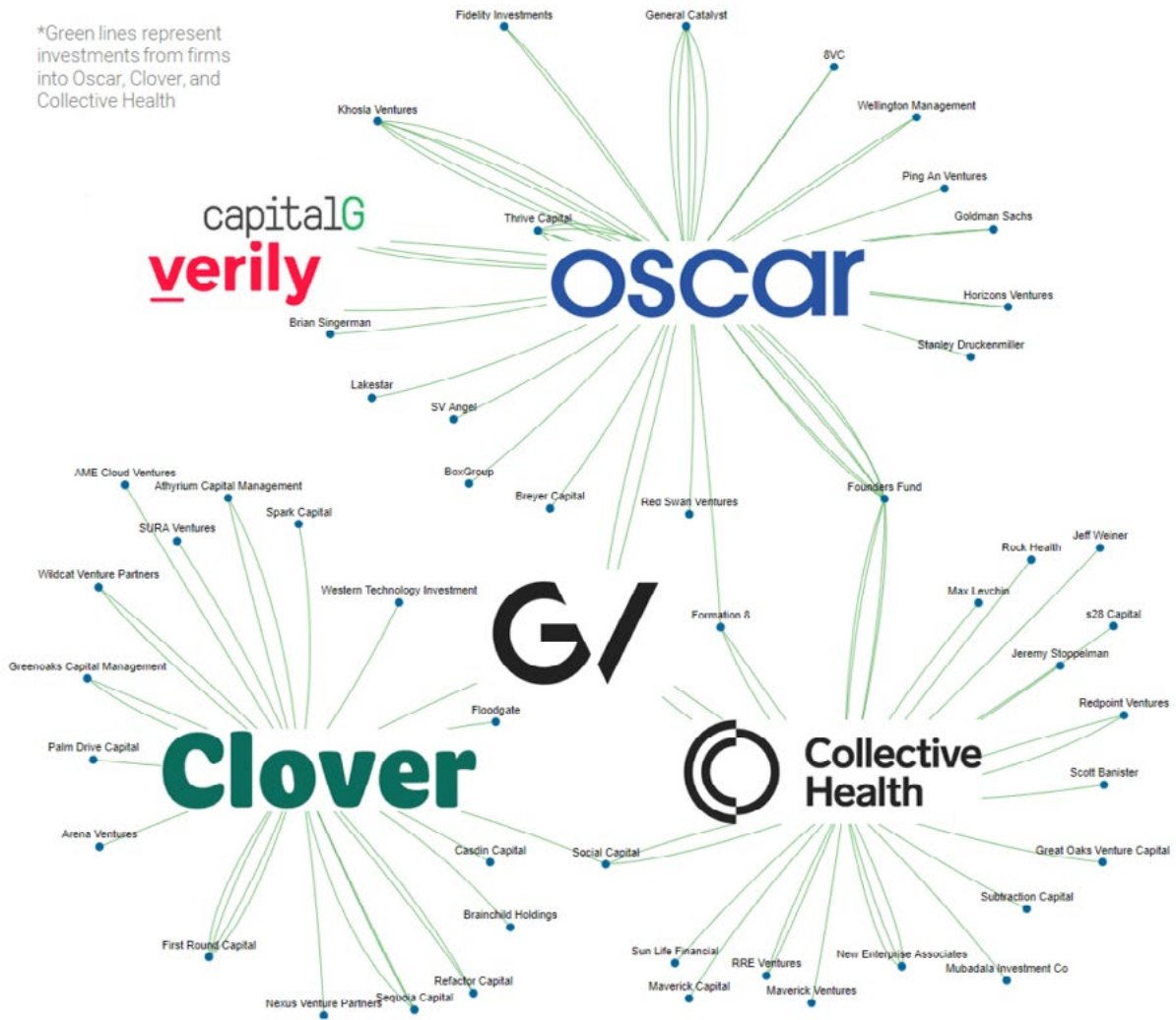

HOW WILL GOOGLE MAKE MONEY OFF ITS HEALTHCARE INITIATIVES?

While Google's regular business model is primarily advertising, it will likely take different approaches to monetize in healthcare, given privacy concerns around people's health information.

Google could make money as an outsourced prototyping and R&D engine for large medical device and pharma companies. These giants could pay for the IP and technology behind new inventions and then bring their commercialization expertise to bear to actually bring it to market. For example Verily [licensed](#) its smart contact to Novartis in 2014.

Google could also sell products and services itself. Google has begun selling its own lines of AI-differentiated hardware including Google Home, Google Pixel, and more. As medical devices themselves become more AI-differentiated, Google could sell these products itself. This is also true for services like diabetes coaching, which AI could help make much more effective AI and can be sold to employers or insurance companies.

There's also the Google Cloud services suite, which we've touched on throughout. As Google [makes a bigger push](#) with its Google Cloud offering and competes with other tech giants, healthcare is an attractive area to sell their storage and services due to the massive amount of data and computing power healthcare — especially data-driven healthcare — requires.

And of course, Google could also explore making money by taking on more risk and becoming an insurer outright, as discussed.

5

Can Google pull it off?

Google’s initial forays into healthcare have not been successful.

In 2008 the company unveiled its personal health record, Google Health, as well as Google Flu Trends, which used search queries to estimate how many people had contracted the flu and where. Both of those projects were shut down a few years later.

More recently, subsidiary Verily faced significant obstacles in its “tricorder” project. The project involved using nanoparticles and magnets to monitor different proteins, biomarkers, etc. in the body in real time. Initially this was pitched as having potential for early cancer and disease detection, and even a universal diagnostic tool. However, the project never materialized, for undisclosed reasons.

Verily Gets More Realistic

“Only through the truth are we going to defeat Mother Nature”

– December 7th, 2015

“Mother Nature defeated us wildly”

– April 19th, 2017



Andrew Conrad, CEO Verily

“WE’RE HOPING TO BUILD THE TRICORDER”

October 28th, 2014

WIRED

Google’s Verily Star Trek “Tricorder” moonshot flops

June 8th, 2016

+MASS DEVICE

But constant experimentation is a good thing, and Google has seemingly learned and iterated from its past failures.

The company is looking at more commercial and realistic solutions, instead of just “moonshots.” It’s working with existing players in the health system, finding ways to apply AI in different areas, and generally finding ways to work around the constraints of the existing medical record system – which was arguably one of the factors that led to the demise of Google Health.

For example, the company is seeing its first commercial product

rollout with Onduo, an improved diabetes management system.

While Google is aiming to fix healthcare with AI, the company still must deal with the issues of public perception and trust. Considering the sensitivity of health data, consumers' trust in Google's ability to keep their personal data private is vital.

Consumers don't hold Google in a high opinion in this regard. The fact that Google is primarily an advertising company that benefits financially from collecting increasingly personal information probably does not help. Additionally, the company has come under some scrutiny involving the legality of how DeepMind was using patient data from the NHS.

How Much Do You Trust Google To Keep Your Personal Health Data Private?

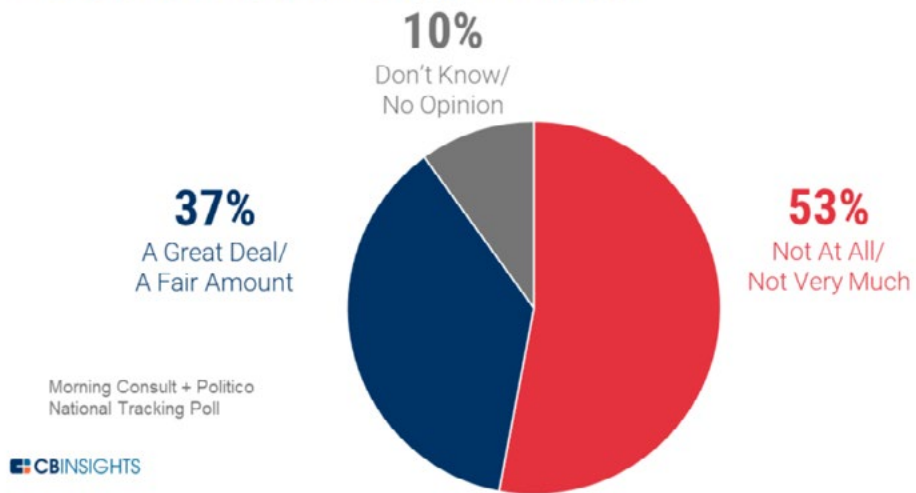

In addition to grappling with public perception, Google will also have to overcome some of its internal issues.

Google, and Verily in particular, has had some troubles retaining employees, including higher-level hires like Calico's ex-chief computing officer Daphne Koller, ex-president of Calico R&D Hal Barron, and Verily's ex-head of mental health projects Thomas Insel. Some reports suggest that this is due to leadership and management; [Glassdoor](#) reviews suggest this is possibly due to compensation and a lack of upward mobility.

Verily organization size has stagnated

Approximate Verily employee count, 2015 - 2018 YTD

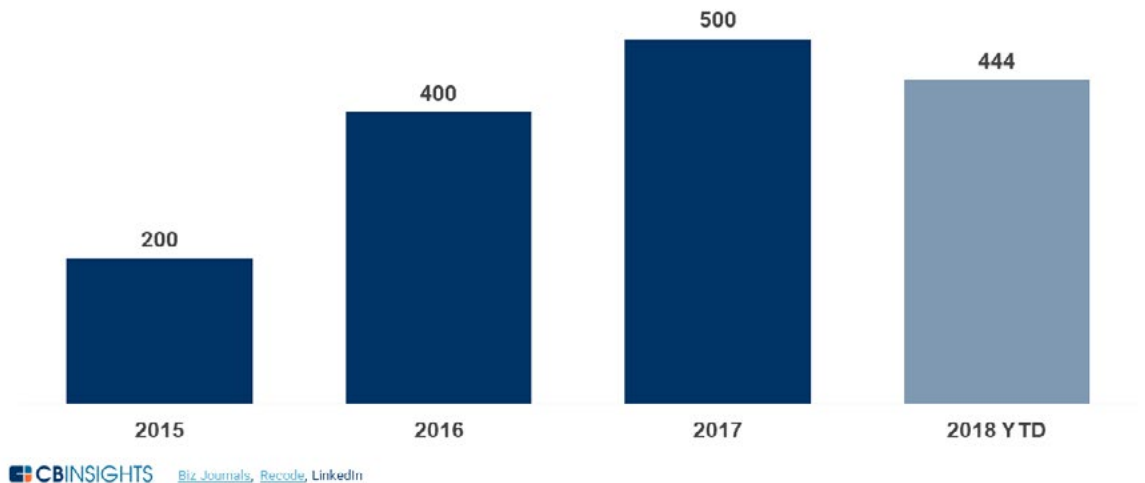

Mapping out Google's health initiatives, it appears the company is working across many different arms that have yet to come together cohesively. This could be one of the drawbacks to Google splitting into subsidiaries. Eventually, the company will want to implement the lessons and most successful projects from across its various organizations into cohesive solutions.

In terms of applying AI to healthcare, Google is aiming to be the new lens for diagnostics and treatment. The company is trying a spray-and-pray approach to finding areas to implement AI, as opposed to concentrating in a few projects.

Based on the above analysis, Google's most likely areas of success will likely come in augmenting providers' ability to detect, triage, and plan around disease, especially in cases that use imaging as a means to do so (eye disease, cancer, etc.).

We can expect Google to face more difficulties in developing hardware, and the verdict's out on how it will differentiate new lifestyle management solutions like Onduo from existing solutions like Omada Health.

Google is working on so many initiatives focused on so many different facets of healthcare across so many areas of the company that the chances of failure are high. But so is potential for success.

Ultimately, if Google can find effective solutions for any one of the many issues it's tackling, there's a potential to apply lessons and successful approaches elsewhere, and create a new data- and AI-driven healthcare paradigm.



START YOUR FINANCE



起点财经，网罗天下报告